

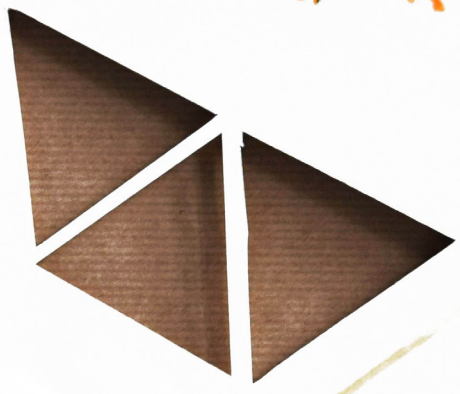

ΠΛΟΤΕΣ ΔΟΜΕΣ ΓΙΑ ΜΙΑ ΠΕΙΡΑΜΑΤΙΚΗ ΚΟΙΝΟΤΗΤΑ



Συχνείο συνάντησης :
ΛΙΜΝΗ ΣΑΕΡΕΥΣΚΑΥΕ



ΔΕΠΑΣΤΑ ΛΗΔΑ
ΔΡΟΣΟΥ ΕΥΑΓΓΕΛΙΑ
ΚΑΡΑΣΑΡΙΝΗ ΚΩΝ/ΝΑ

ΜΑΡΤΙΟΣ 2019

ΕΠΙΒΛΕΠΟΝΤΕΣ:

ΣΤΑΥΡΟΣ ΣΤΑΥΡΙΔΗΣ
ΚΩΣΤΑΣ ΚΑΡΑΔΗΜΑΣ

ΔΙΠΛΩΜΑΤΙΚΗ ΕΡΓΑΣΙΑ
ΣΧΟΛΗ ΑΡΧΙΤΕΚΤΟΝΩΝ ΜΗΧΑΝΙΚΩΝ

ΠΕΡΙΟΧΗ ΚΑΙ ΑΝΑΛΥΣΗ

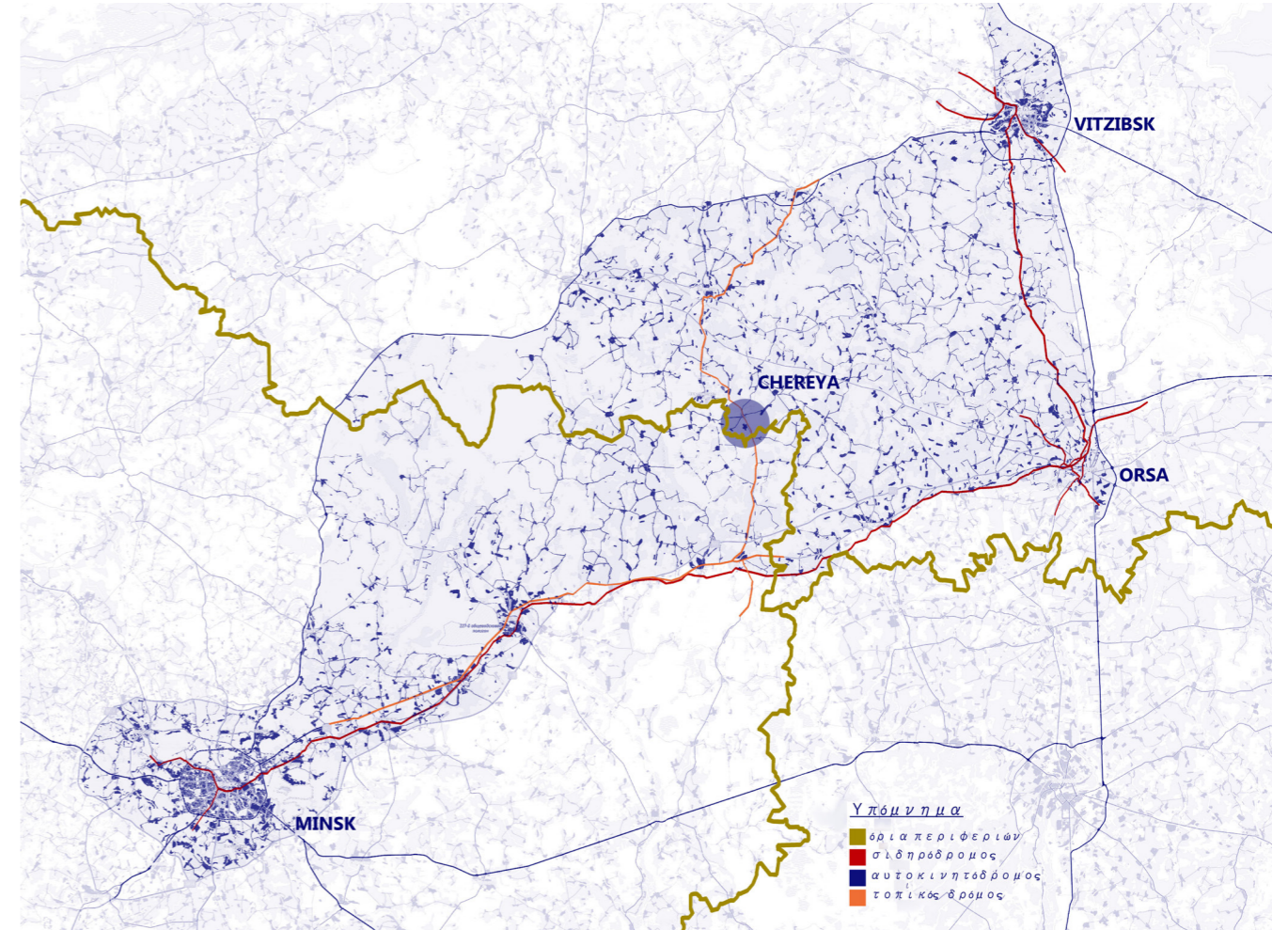
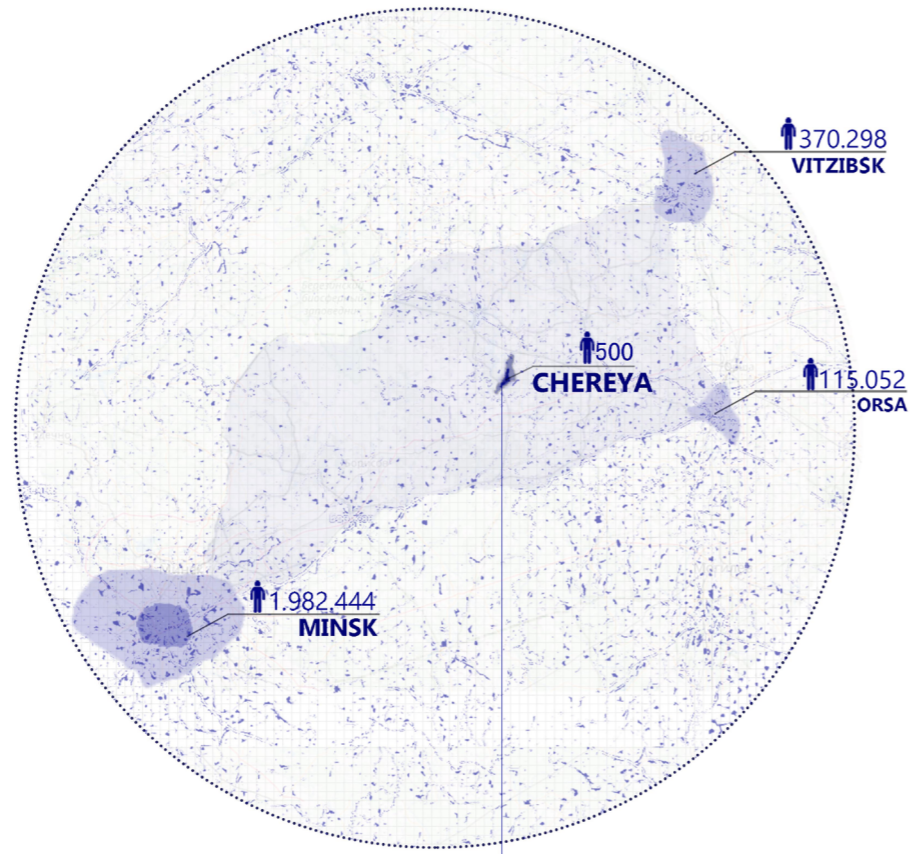

Μινσκ, Μάιος 2018



χάρτης 19ου αιω: τα χωριά, η λίμνη και η εκκλησία



άποψη της λίμνης από ψηλά



Μινσκ, Μάιος 2018

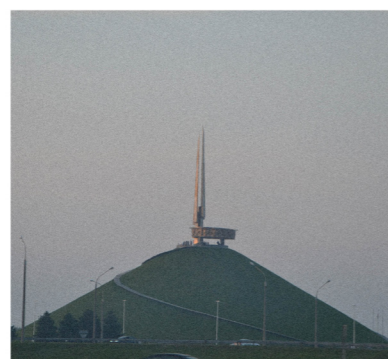

Μινσκ, Μάιος 2018

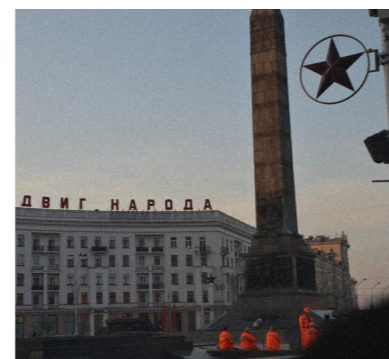

Μινσκ, Μάιος 2018

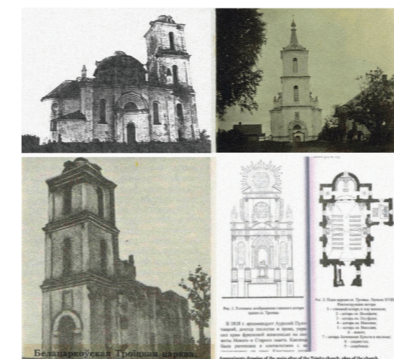

η εκκλησία 16ος-18ος αιω, αρχείο της βιβλιοθήκης της Chereya



η χερσόνησος, η λίμνη και η εκκλησία

ΣΥΝΘΕΣΗ ΤΗΣ ΠΡΟΣΛΗΨΗΣ ΤΟΥ ΤΟΠΙΟΥ - ΤΑ ΧΩΡΙΑ, Η ΛΙΜΝΗ ΚΑΙ Ο ΟΡΙΖΟΝΤΑΣ



Η ΕΚΚΛΗΣΙΑ ΩΣ ΣΤΑΘΕΡΟ ΣΗΜΕΙΟ ΑΝΑΦΟΡΑΣ



η χερσόνησος και η εκκλησία

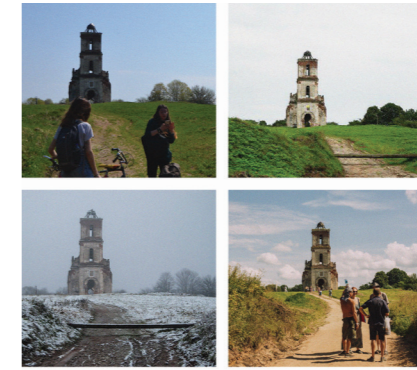

προσεγγίζοντας την εκκλησία - κύρια όψη



κάδρα μέσα από την εκκλησία



δίπολα: χειμώνας- καλοκαίρι, μέρα- νύχτα, ζωντανό- έρημο τοπίο



η εναλλαγή των εποχών -μεταβαλλόμενο τοπίο



η εκκλησία ως σημείο αναφοράς στην Belaya Tserkva

ΟΙ ΑΝΘΡΩΠΟΙ ΚΑΙ ΟΙ ΔΡΑΣΕΙΣ ΤΟΥ ΤΟΠΟΥ



υπαίθριο θέατρο, αρχιτεκτονικό εργαστήριο Sesam Ex Nihilo, Μάιος 2018



στάση λεωφορείου, αρχιτεκτονικό εργαστήριο Sesam Ex Nihilo



πλωτή πλατφόρμα, αρχιτεκτονικό εργαστήριο Sesam Ex Nihilo



φεστιβάλ Sprava



φεστιβάλ Sprava, η παράδοση ως αναπόσπαστο στοιχείο



φεστιβάλ Sprava

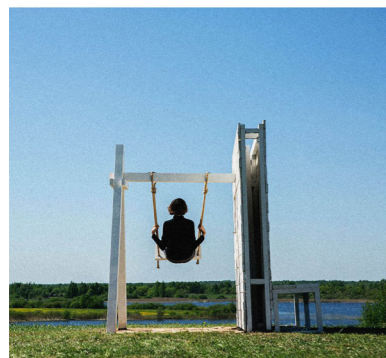

αρχιτεκτονικό εργαστήριο Sesam Ex Nihilo



περίγραμμα του παλιού ιερού, αρχιτεκτονικό εργαστήριο Sesam Ex Nihilo



αρχιτεκτονικό εργαστήριο Sesam Ex Nihilo



φεστιβάλ Sprava



κατοικώντας για δύο μέρες στη χερσόνησο, στο πλαίσιο του φεστιβάλ



η παράδοση, τα ήθη και τα έθιμα



το χωριό αποκτά ζωή για δέκα μέρες, Sesam Ex Nihilo



κατοίκηση στο εγκαταλελειμμένο σχολείο, Sesam Ex Nihilo



κατοίκηση στο εγκαταλελειμμένο σχολείο



στοιχεία αυτοκατασκευής



αυτοσχέδιο υπαίθριο καθιστικό



εμπλοκή και συνεισφορά της τοπικής κοινότητας στο φεστιβάλ

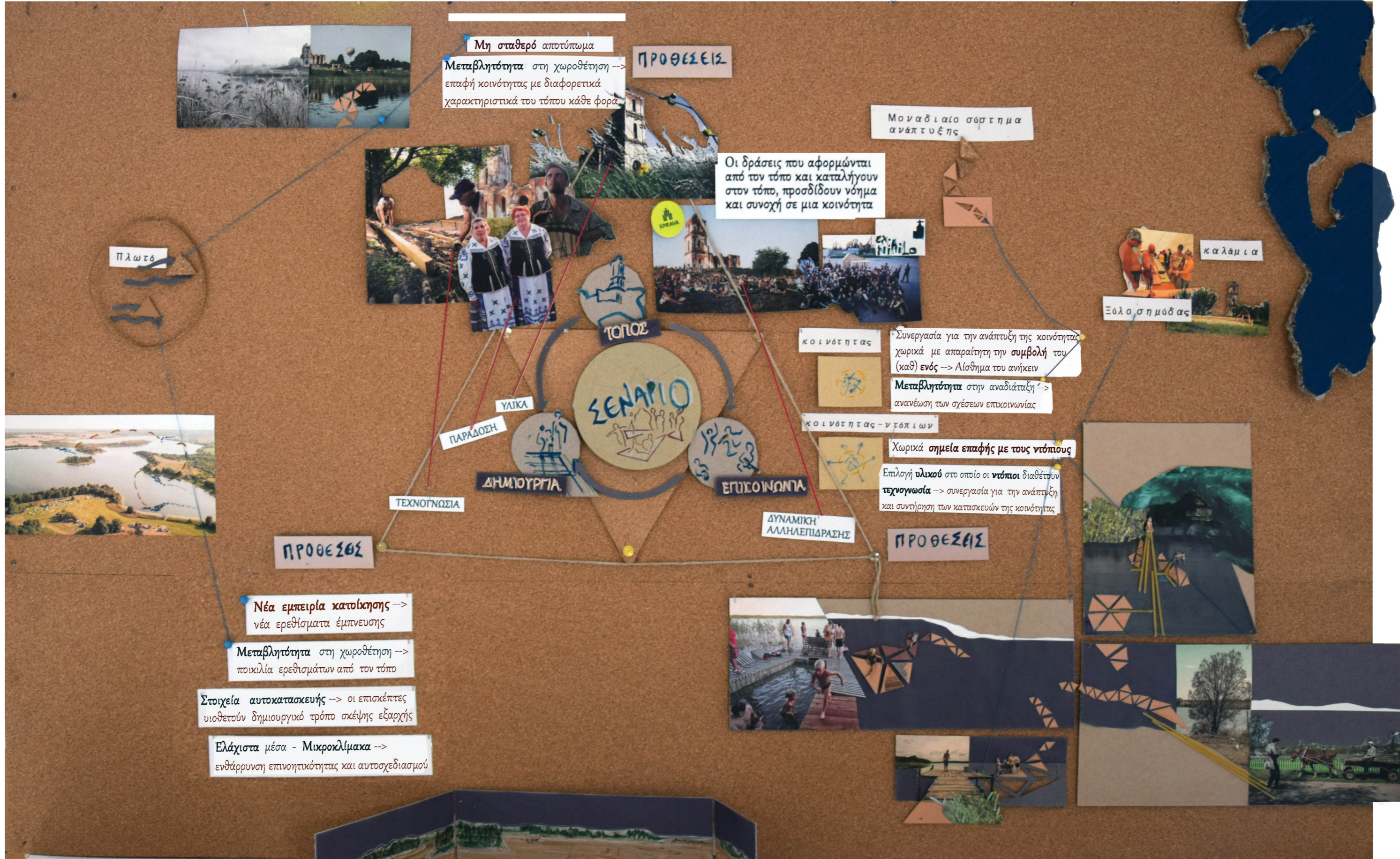

ΤΟΠΙΑΚΗ ΑΝΑΛΥΣΗ ΠΡΟΣ ΑΝΑΖΗΤΗΣΗ ΟΡΙΑ



Πράσινο

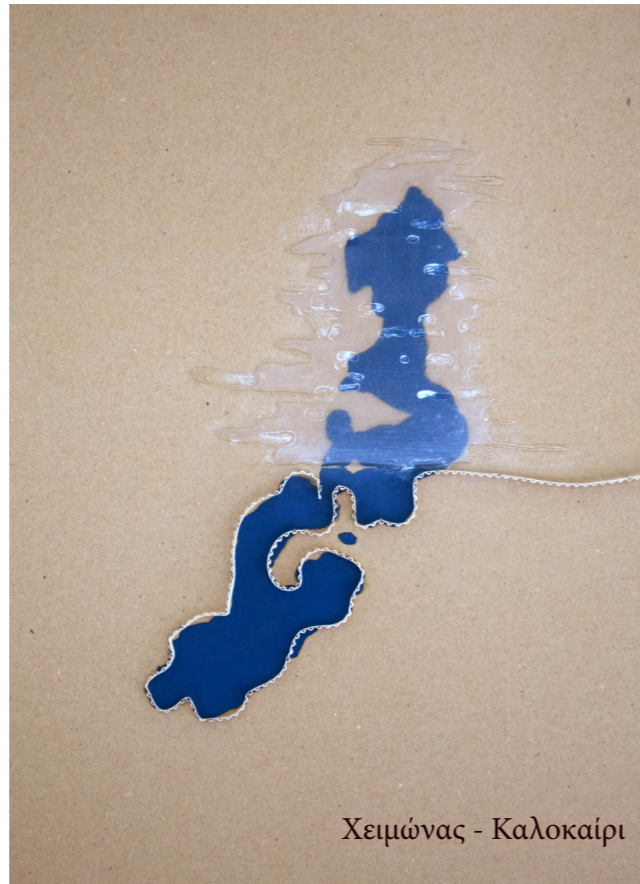

Χειμώνας - Καλοκαίρι

ΘΕΣΕΩΝ ΠΑΡΕΜΒΑΣΗΣ ΓΕΩΜΕΤΡΙΑ

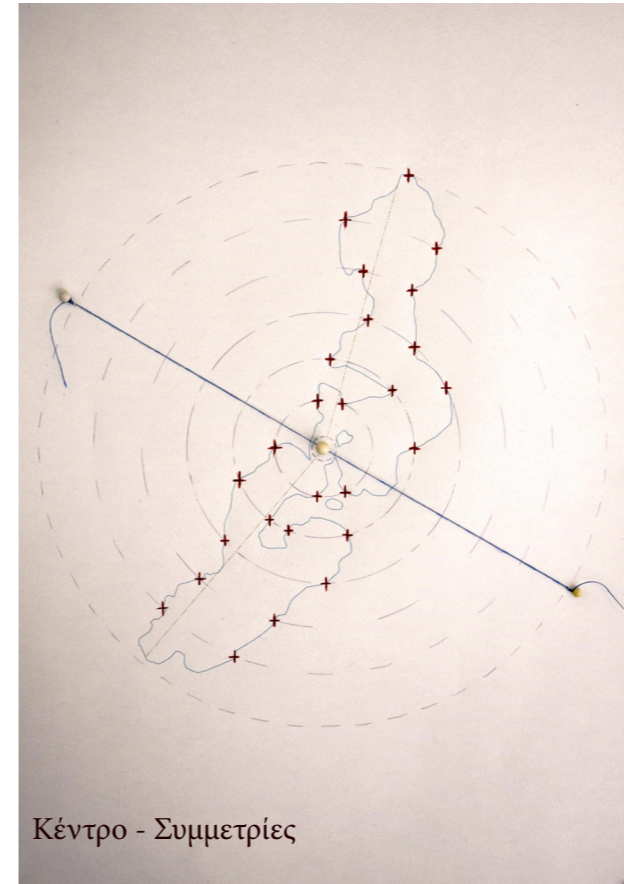

Κέντρο - Συμμετρίες



Κυρτό - Κοίλο | Κλίμακα

ΙΣΤΟΡΙΑ



Τοπίο - Τοπόσημα

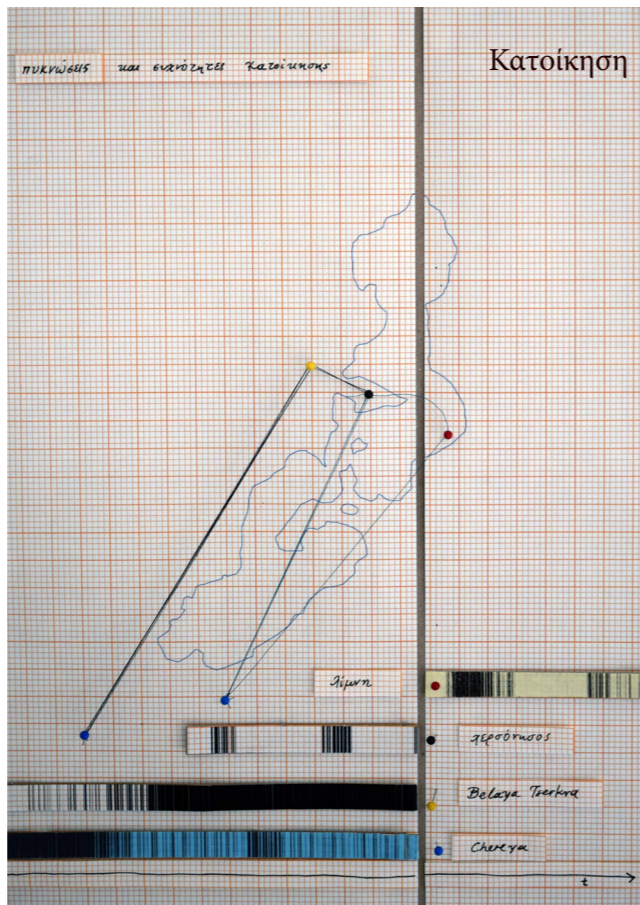

Κατοίκηση

ΣΤΟΙΧΕΙΑ ΖΩΗΣ

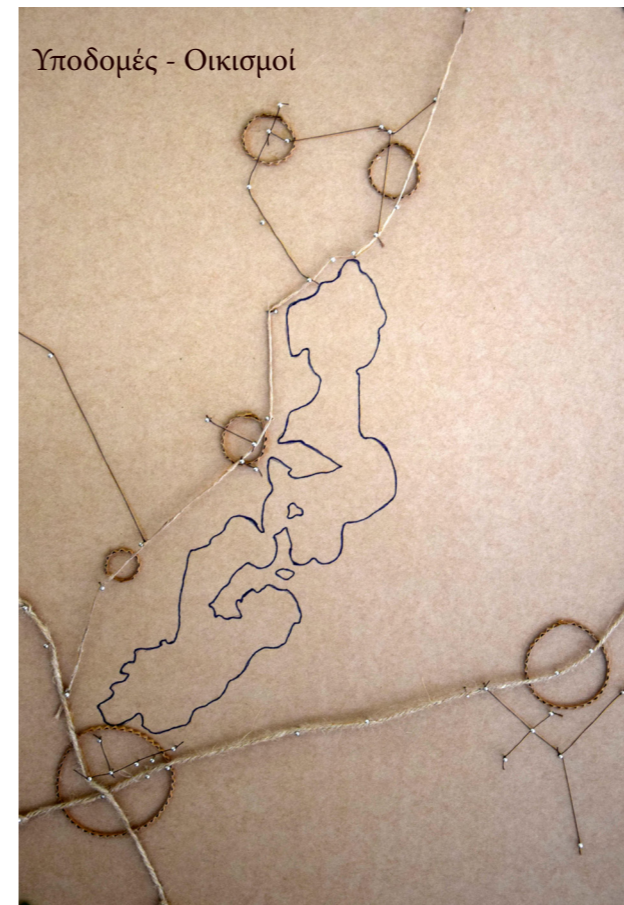

Υποδομές - Οικισμοί



Ροές - Βιότοποι

ΕΠΙΛΕΓΜΕΝΑ ΣΗΜΕΙΑ ΠΑΡΕΜΒΑΣΗΣ

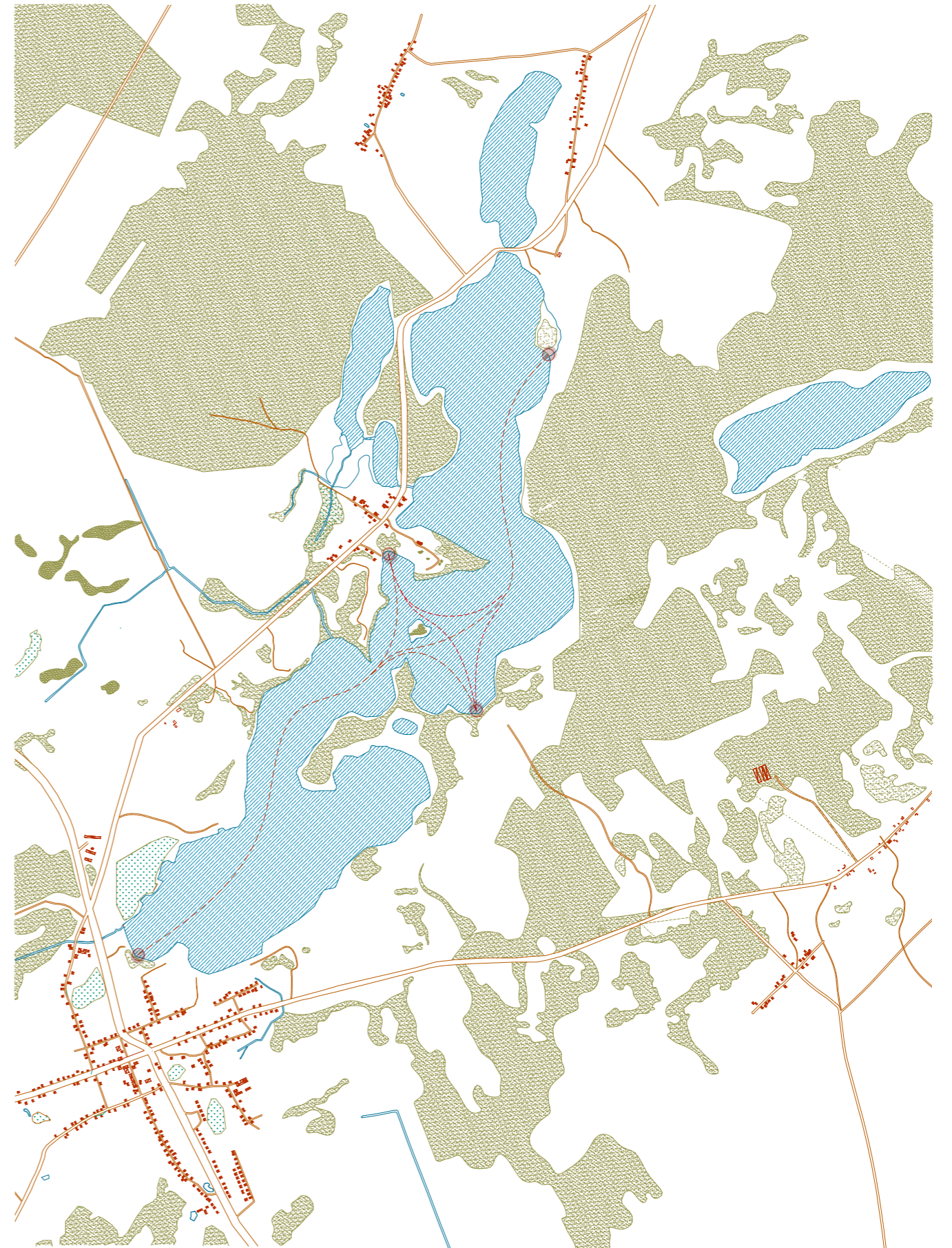

ΜΟΝΑΔΑ ΟΙΚΙΣΜΟΥ



|ΚΛΙΜΑΚΑ 1:10

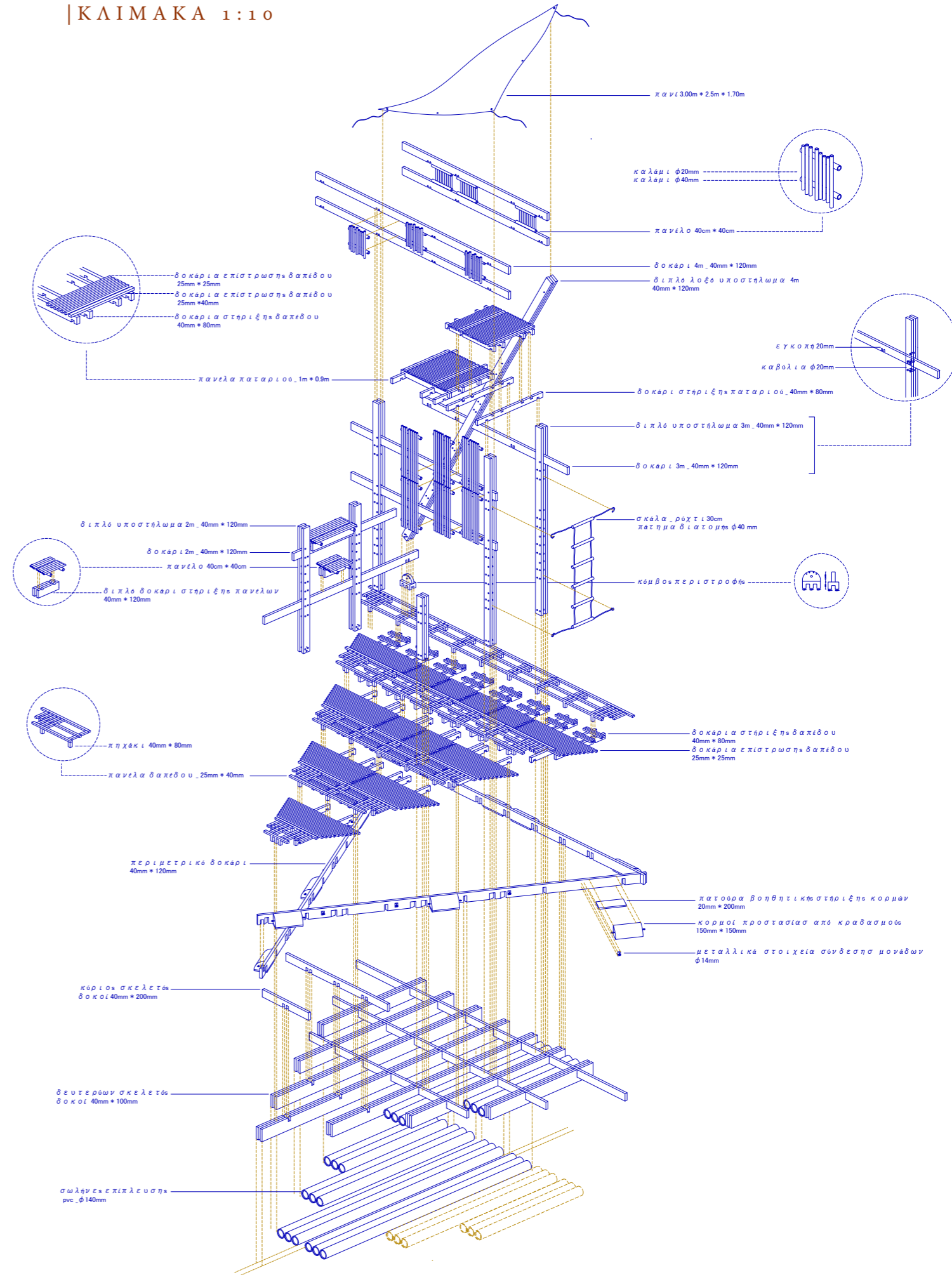

ΚΙΟΣΚΙ ΑΦΕΤΗΡΙΑΣ ΟΙΚΙΣΜΟΥ

| ΚΛΙΜΑΚΑ 1:100

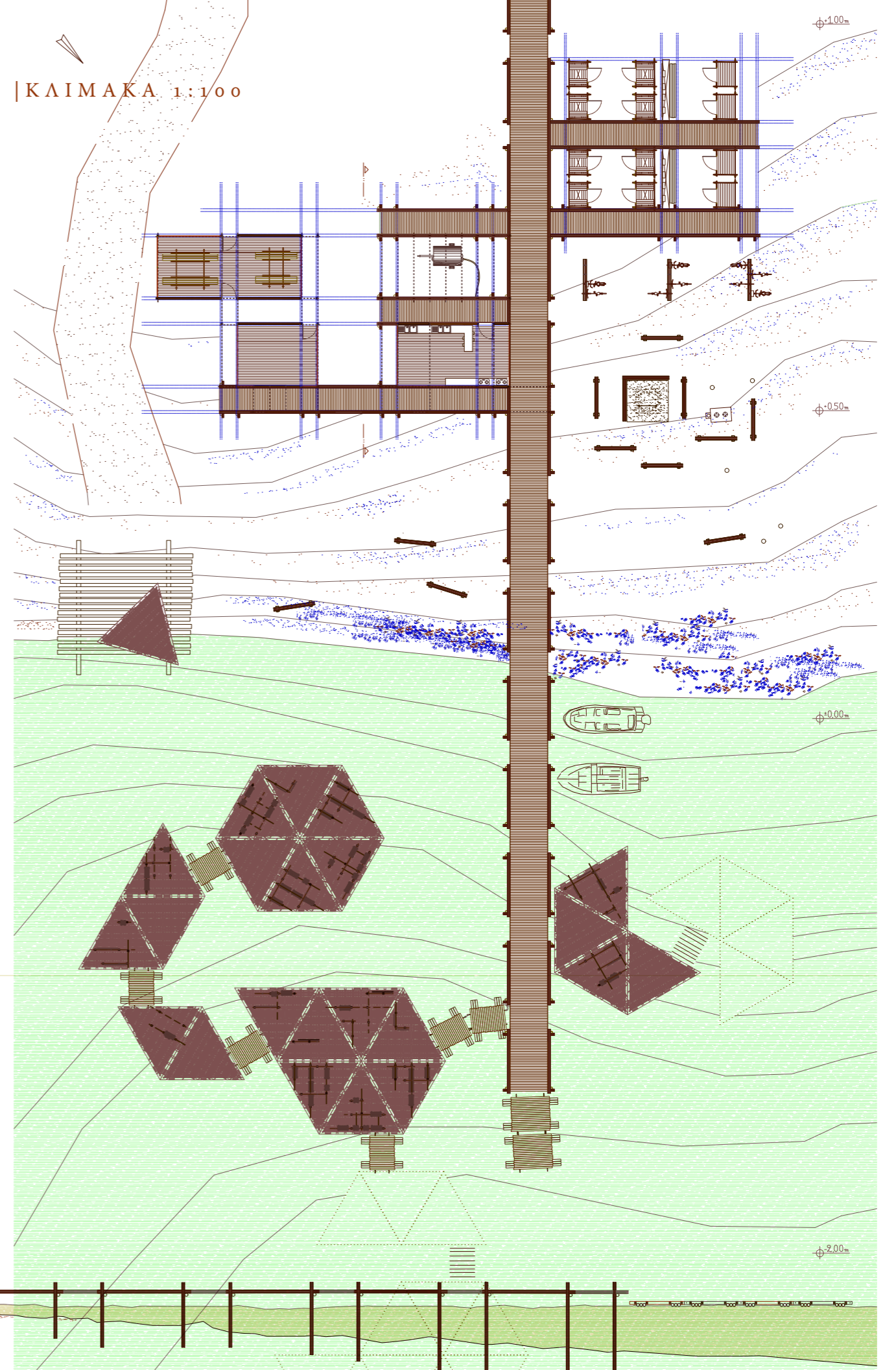
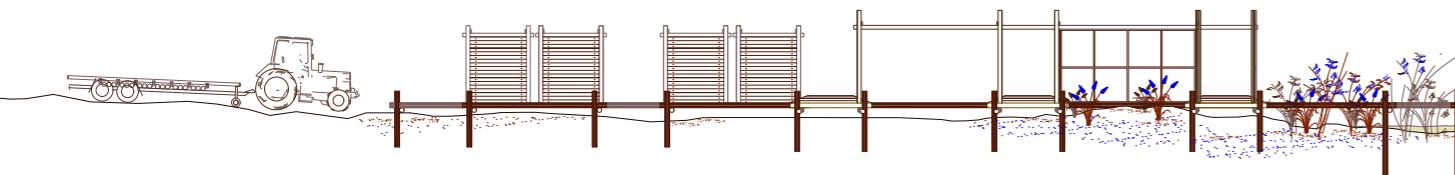
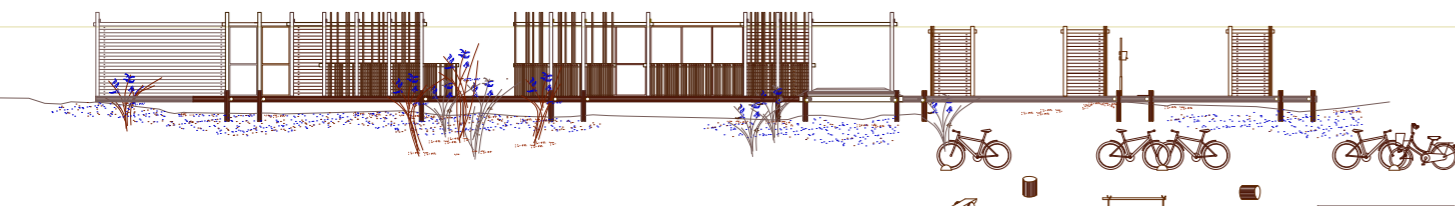
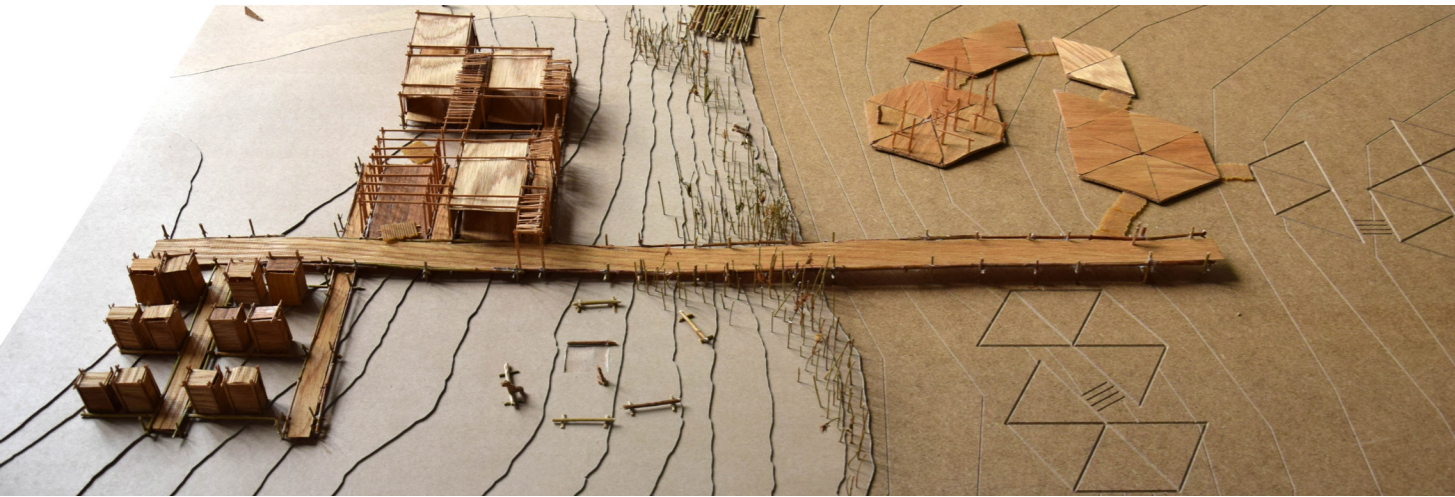

ΣΤΙΓΜΙΟΤΥΠΑ ΔΙΑΤΑΞΗΣ ΟΙΚΙΣΜΩΝ ΑΝΑ ΛΙΜΑΝΙ

| ΚΛΙΜΑΚΑ 1:500

ΣΧΕΣΗ ΜΕ ΤΗΝ ΟΧΘΗ

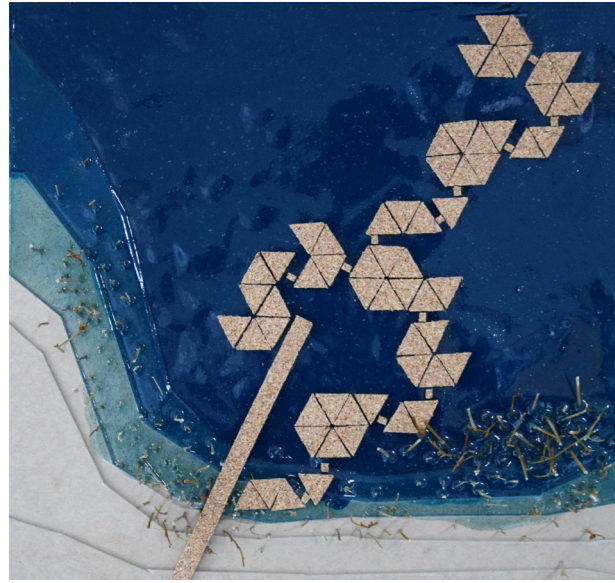

ΠΑΡΑΛΛΑΓΕΣ ΕΣΩΤΕΡΙΚΩΝ ΣΧΕΣΕΩΝ

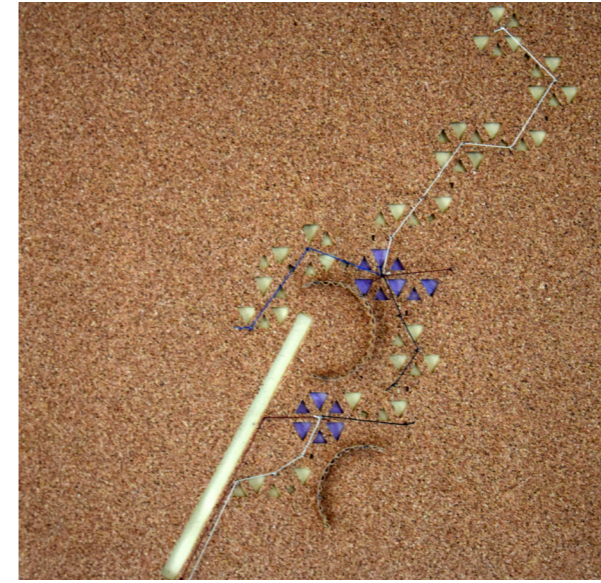
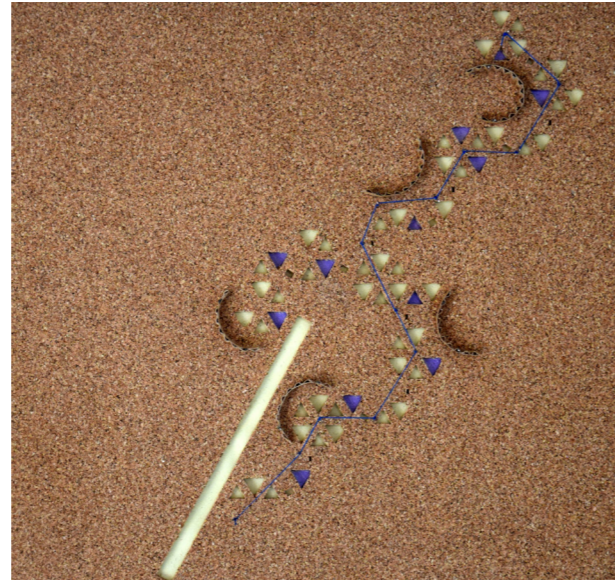

▲ κοινόχρηστες μονάδες
▲ ιδιωτικές μονάδες

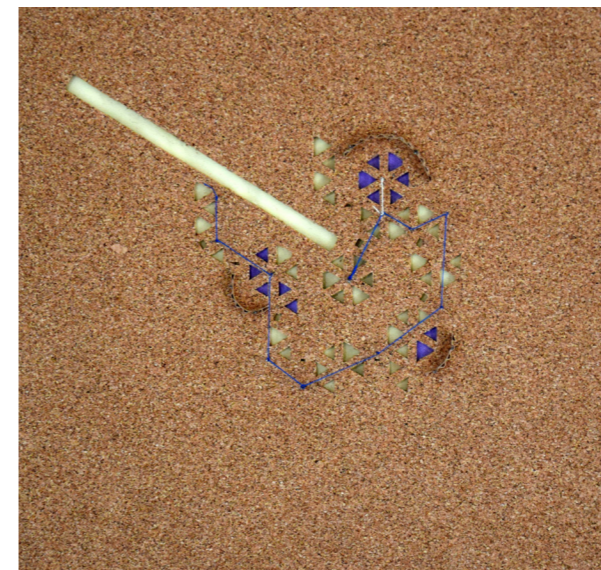
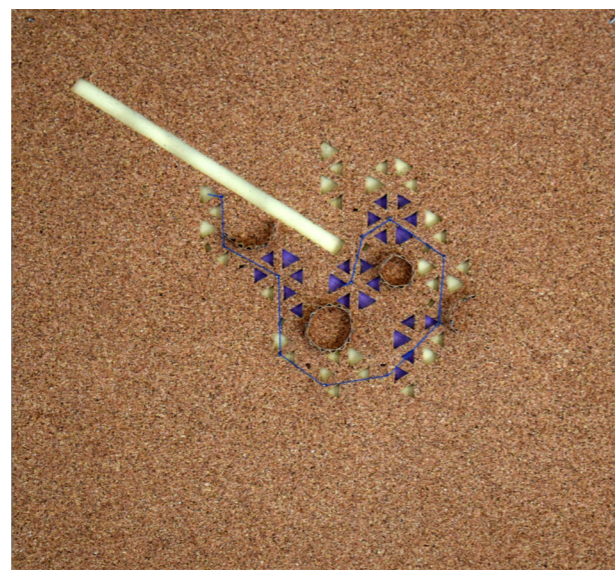
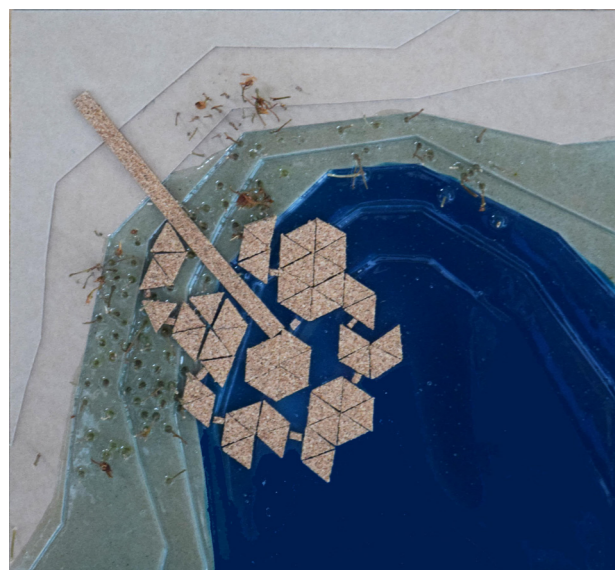
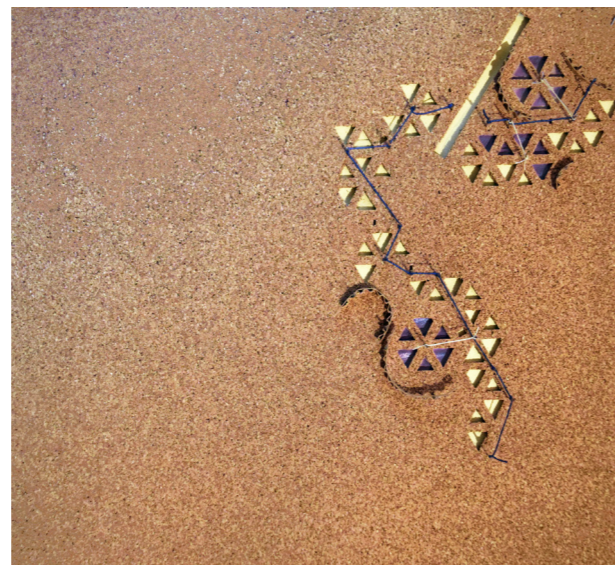
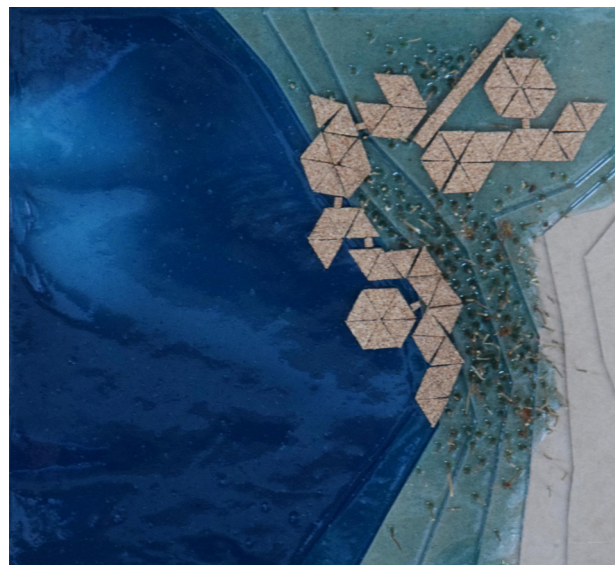

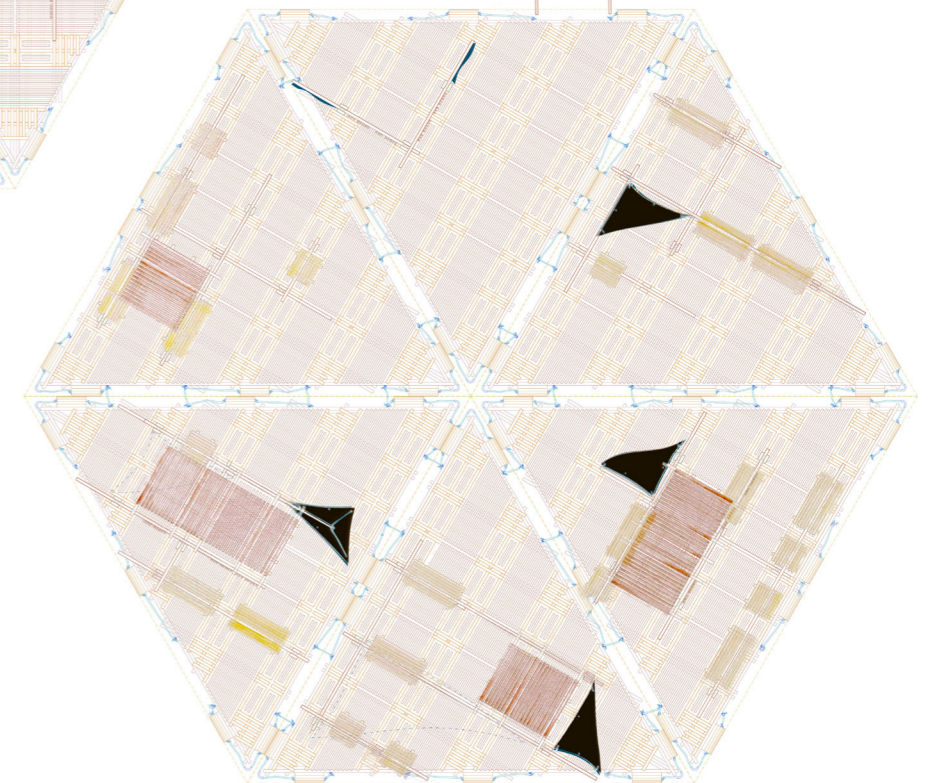
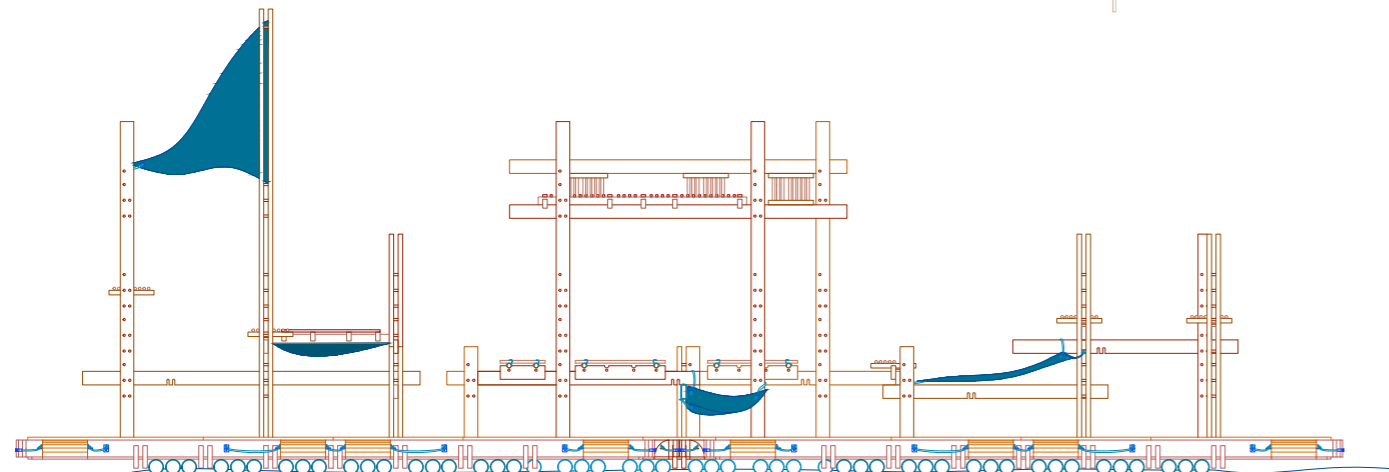
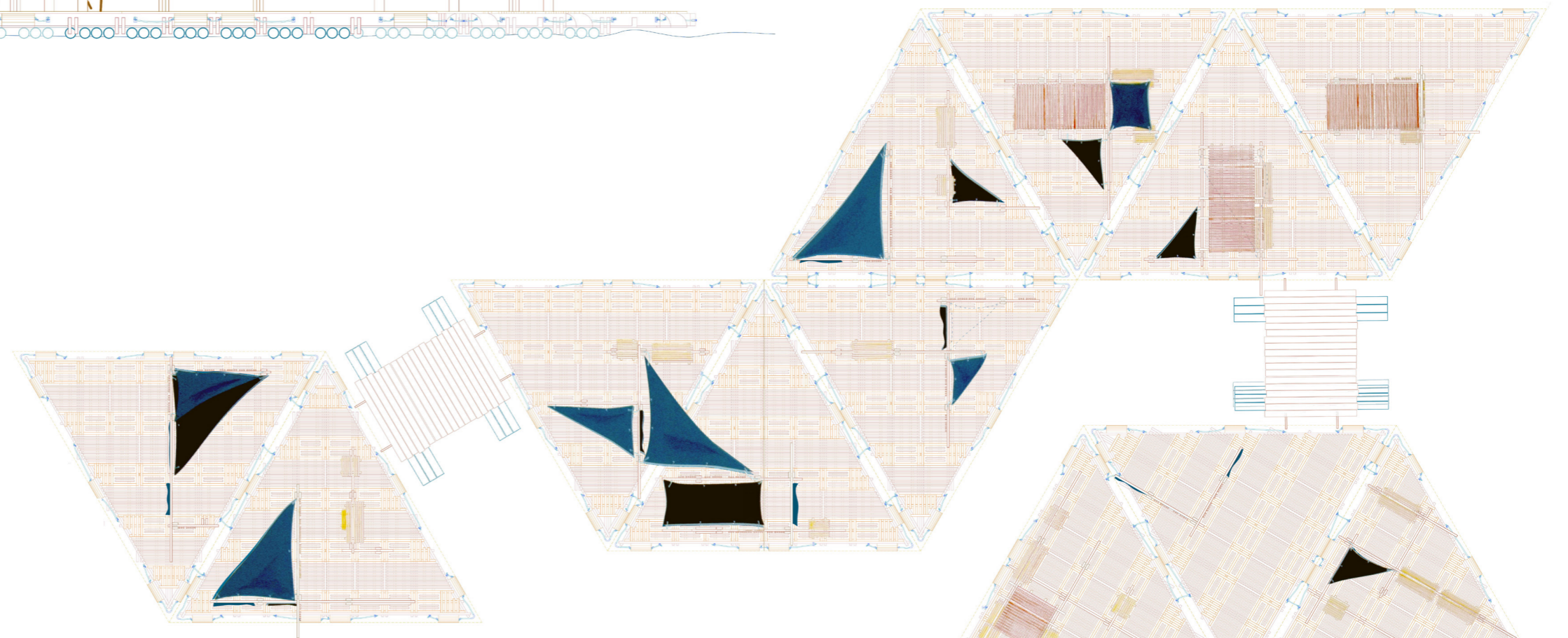
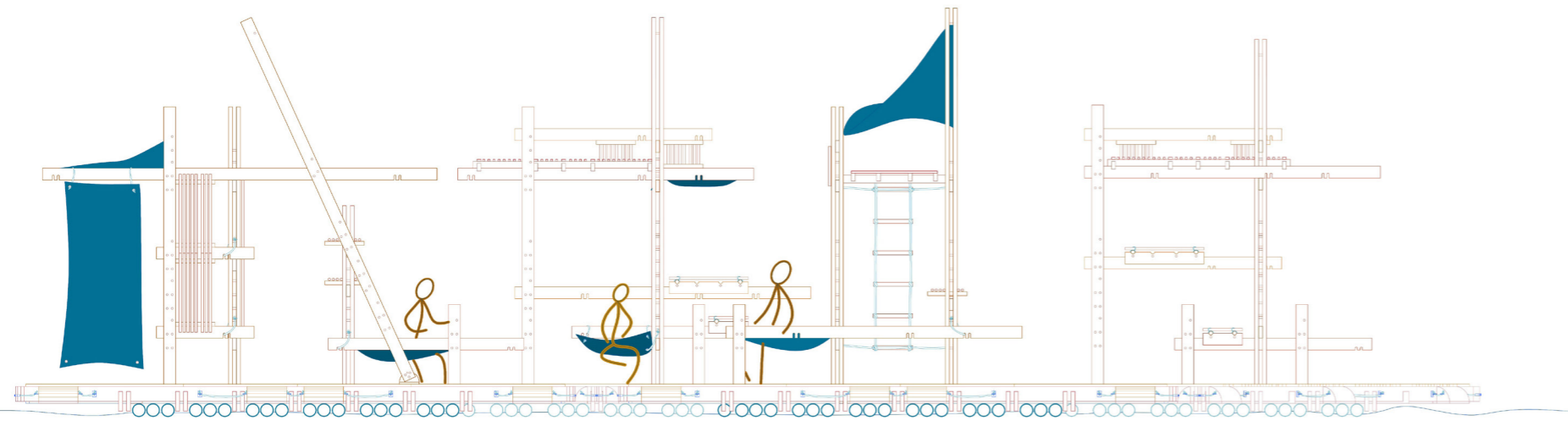

στοιχεία

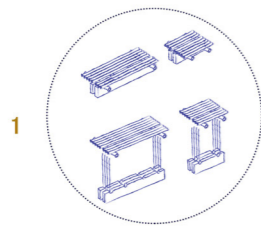
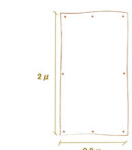
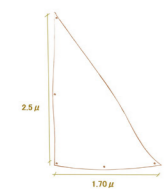
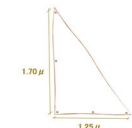
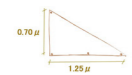
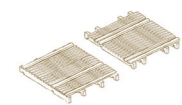
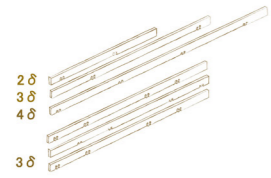

1

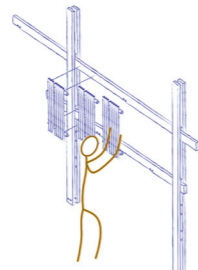

πάνελο

2

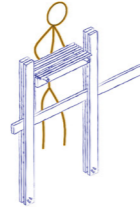
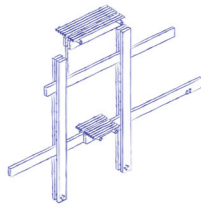

3

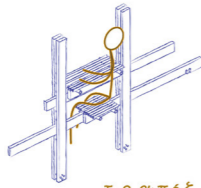

τραπέζι

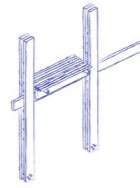

κάθισμα

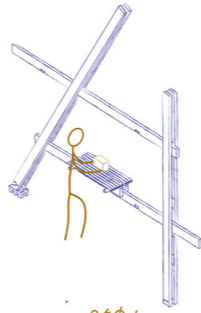

ράφι

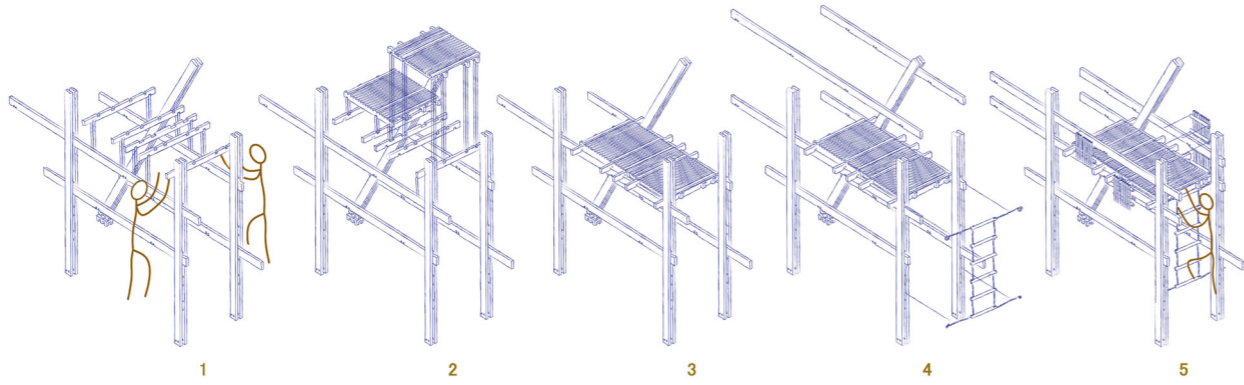

1

2

3

4

5

πατάρι

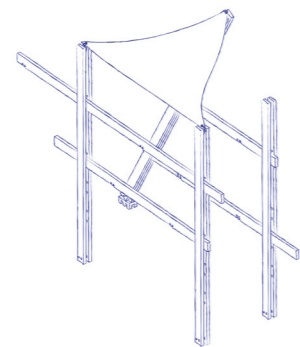

σκιάστρο

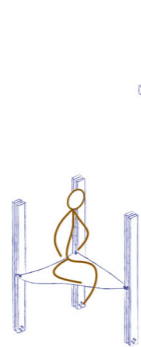

κάθισμα

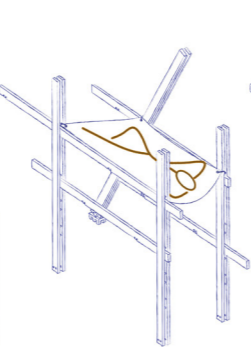

αιώρα

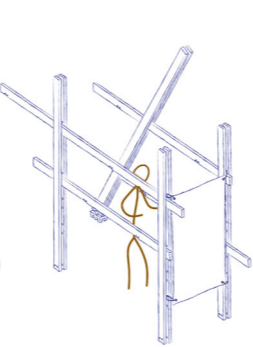

στοιχείο
πλήρωσης

